

# BERGMANN II C 815 s

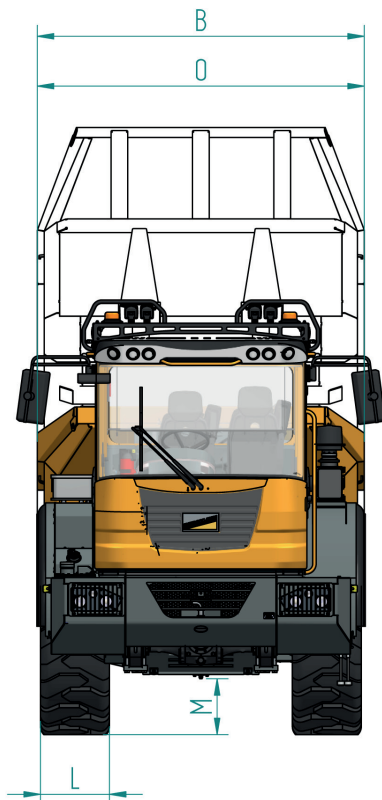

## Rear tip dumper

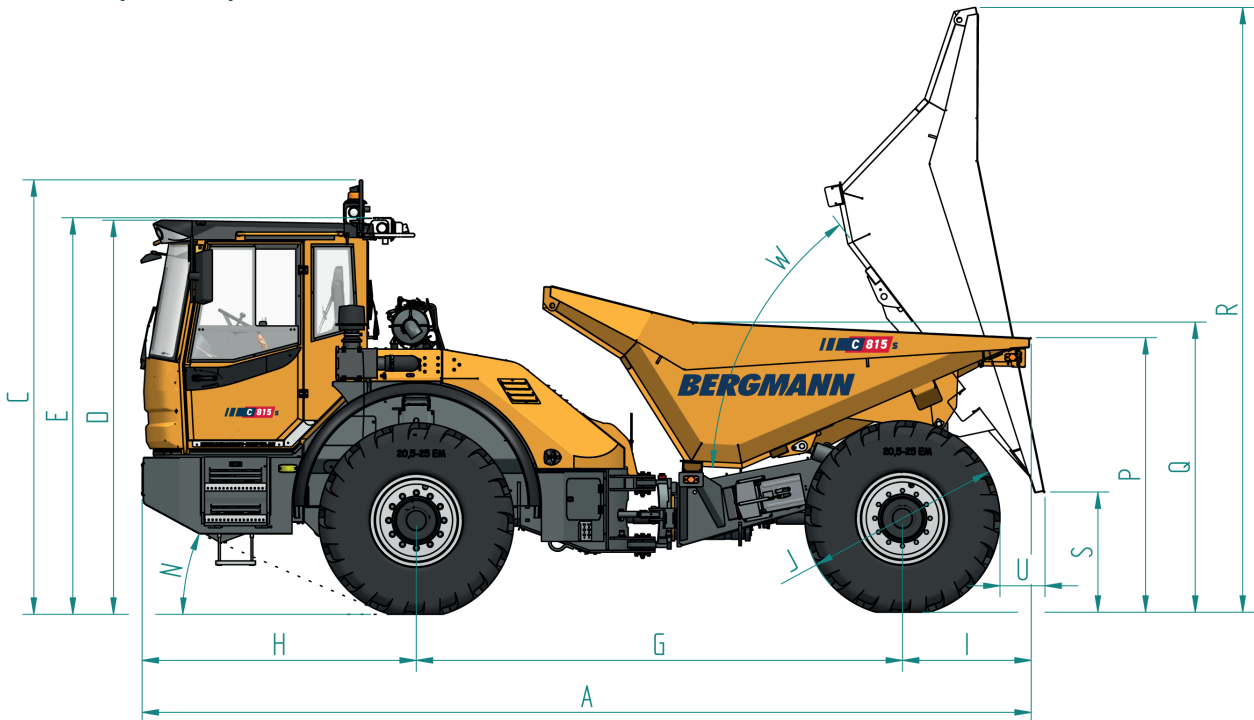

### Dimensions

A	6,834 mm	22.42 ft
B	2,505 mm	8.22 ft
C	3,338 mm	10.95 ft
D	3,028 mm	9.93 ft
E	3,047 mm	10.00 ft
G	3,737 mm	12.26 ft
H	2,108 mm	6.92 ft
I	989 mm	3.24 ft
J	1,500 mm	4.92 ft
L	529 mm	1.74 ft
M	429 mm	1.41 ft
O	2,505 mm	8.22 ft
P	2,110 mm	6.92 ft
Q	2,230 mm	7.32 ft
R	4,647 mm	15.25 ft
S	923 mm	3.03 ft
W		76°

### Weight

Empty weight	9,080 kg	20,017 lb
Payload	12,000 kg	26,455 lb

### Bucket capacity

Struck	5 m <sup>3</sup>	6.5 yd <sup>3</sup>
Heaped	8 m <sup>3</sup>	10.5 yd <sup>3</sup>

All illustrations, dimensions and weights do not necessarily correspond to the standard equipment and are non-binding with regard to tolerance deviations on component level. We reserve the right to make technical changes.

# BERGMANN II C 815 s



## Three-way tip dumper

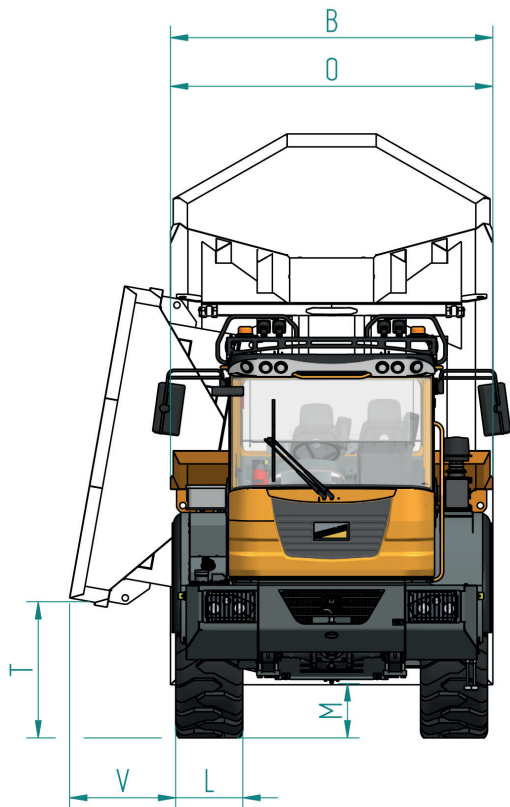
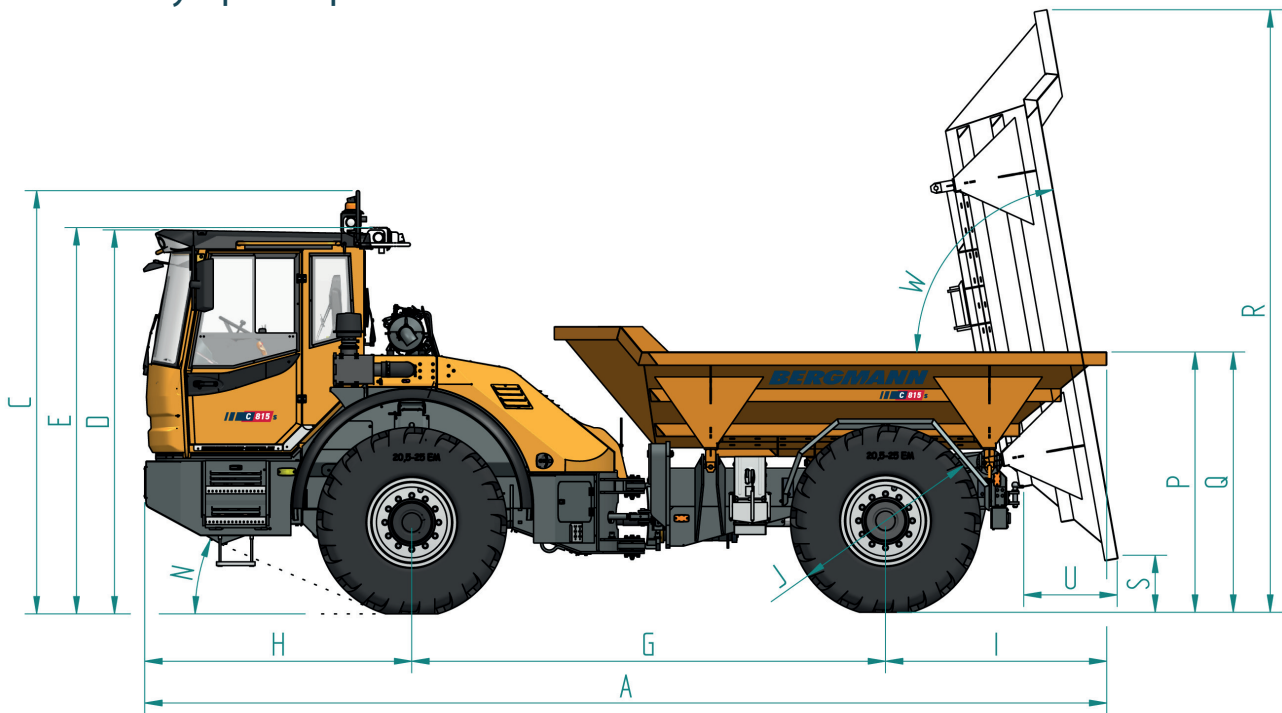

### Dimensions

A	7,593 mm	24.91 ft
B	2,541 mm	8.34 ft
C	3,338 mm	10.95 ft
D	3,028 mm	9.93 ft
E	3,047 mm	10.00 ft
G	3,739 mm	12.27 ft
H	2,107 mm	6.91 ft
I	1,746 mm	5.73 ft
J	1,500 mm	4.92 ft
L	529 mm	1.74 ft
M	429 mm	1.41 ft
N		23°
O	2,541 mm	8.34 ft
P	2,052 mm	6.73 ft
Q	2,052 mm	6.73 ft
R	4,752 mm	15.59 ft
S	449 mm	1.47 ft
T	1,075 mm	3.53 ft
U	738 mm	2.42 ft
V	836 mm	2.74 ft
W		80°

### Weight

Empty weight	10,020 kg	22,090 lb
Payload	12,000 kg	26,455 lb

### Bucket capacity

Struck	4,2 m <sup>3</sup>	5.5 yd <sup>3</sup>
Heaped	8 m <sup>3</sup>	10.5 yd <sup>3</sup>

All illustrations, dimensions and weights do not necessarily correspond to the standard equipment and are non-binding with regard to tolerance deviations on component level. We reserve the right to make technical changes.



# BERGMANN II C 815 s



Swivel-tip dumper

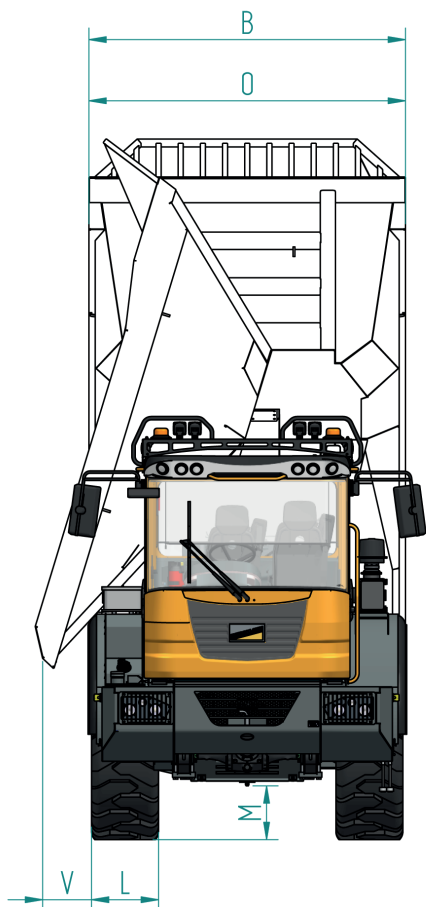

## Dimensions

A	7,129 mm	23.39 ft
B	2,500 mm	8.20 ft
C	3,338 mm	10.95 ft
D	3,028 mm	9.93 ft
E	3,047 mm	10.00 ft
G	3,659 mm	12.00 ft
H	2,107 mm	6.91 ft
I	1,362 mm	4.47 ft
J	1,500 mm	4.92 ft
L	529 mm	1.74 ft
M	424 mm	1.39 ft
N		23°
O	2,500 mm	8.20 ft
P	2,273 mm	7.46 ft
Q	2,442 mm	8.01 ft
R	5,516 mm	18.10ft
S	1,441 mm	4.73 ft
U	246 mm	0.81 ft
V	386 mm	0.99 ft
W		46°

## Weight

Empty weight	11,140 kg	24,559 lb
Payload	12,000 kg	26,455 lb

## Bucket capacity

Struck	6.3 m <sup>3</sup>	8.5 yd <sup>3</sup>
Heaped	8 m <sup>3</sup>	10.5 yd <sup>3</sup>

All illustrations, dimensions and weights do not necessarily correspond to the standard equipment and are non-binding with regard to tolerance deviations on component level. We reserve the right to make technical changes.

## Technical data

### Highlights

- High stability thanks to oscillating axle
- Swivelling operator's stand
- Electro hydraulic spring type cylinder park brake
- Compact dimensions and low weight

### Engine

4 cylinder Cummins diesel engine – water-cooled

Power	119 kW	159.58 hp
Rotational speed		2,200 rpm
Emission standard		Stage 5

### Transmission

Load-depending shift – manually shiftable by hand and automatically, self-adjusting optimisation of traction force and speed, speed control stepless forward and backwards, ZF-Ergo-Power transmission

1. gear f/b	6/6 km/h	3.7/3.7 mph
2. gear f/b	9/15 km/h	5.6/9.3 mph
3. gear f/b	14/33 km/h	8.7/20.5 mph
4. gear f	21 km/h	13.0 mph
5. gear f	32 km/h	19.9 mph
6. gear f	40 km/h	24.9 mph

### Steering

Hydraulic articulated steering via priority valve; articulated joint: 37° left and right

### Axles/Brakes

- Front axle with leaf spring suspension, rear axle rigid
- Maintenance-free oil-bath multi-disc brake in the wheel hubs with self-locking differential with a locking value of 45 %
- Hydraulically applicated spring-type cylinder locking brake acting over articulated shaft on front and rear axle

### Standard tyres

All tyres 20.5-25 Double Coin  
(more tyre options on request)

### Tank capacity

Fuel	190 L
Hydraulic oil	64 L

### Electrics

- 24 V electric system with main switch
- Fault detection mode
- Control lamps for engine oil, park brake, driving display, battery charging control and hydraulic filter
- Display for drive position

### Standard equipment

- Comfortable driver's cab with air-suspended driver's seat
- Swivelling operator's stand
- Lighting system in accordance with German traffic regulations
- Bucket from wear-resistant fine-grain steel
- Beacon light, cigarette lighter
- Sun blind for front windscreen
- Device for radio, loudspeaker and antenna
- CE conformity declaration
- Manual/Spare parts list